



**Modular Cooking Range Line
900XP Gas Cylindrical Boiling Pan
150lt indirect heat**

ITEM # _____

MODEL # _____

NAME # _____

SIS # _____

AIA # _____



391102 (E9BSGHIRF0) 150-lt gas boiling pan with pressure switch, indirect heating

Short Form Specification

Item No. _____

Suitable for natural gas or LPG. To be installed on cantilever systems but also incorporates fixing points for bridging. Robust burners in stainless steel with flame failure device and protected pilot light. Exterior panels of unit in stainless steel with Scotch Brite finish. Double jacketed lid made in 2mm thick AISI 316 stainless steel. Pressed well with rounded edges manufactured from AISI 316 stainless steel. Right-angled side edges to allow flush-fitting junction between units. Includes safety valve to control working pressure. Temperature limiter for power regulation allowing precise temperature cooking.

Main Features

- Round kettle is suitable to cook, sauté or poach all kinds of produce.
- Produce is uniformly heated in the base and side walls of the kettle by an indirect heating system that uses integrally generated saturated steam at a temperature of 110° C in the jacket.
- External valve allows to manually evacuate excess air accumulated in the jacket during heating phase.
- Appliance is IPX5 water resistance certified.
- Manometer allows to correctly control the functioning of the pan.
- Energy regulation through a control knob.
- Safety thermostat protects against low water level.
- Safety valve avoids overpressure of the steam in the jacket.
- No overshooting of cooking temperatures, fast reaction.
- Large capacity food tap enables safe and effortless discharging of contents.
- Ergonomic: the depth of the vessel facilitates stirring the food, also the most delicate food.
- Discharge tube and tap are very easy to clean from outside.
- Solenoid valve to refill with hot and cold water.
- Smooth large surfaces, easy access for cleaning.
- The special design of the control knob system guarantees against water infiltration.
- Minimum load for correct functioning is 20 liters.

Construction

- Pressed cooking vessel and double jacket in 316 AISI Stainless steel.
- Robust burners in stainless steel with flame failure device, protected pilot light and optimized combustion.
- All exterior panels in Stainless Steel with Scotch Brite finishing.
- Model has right-angled side edges to allow flush fitting joints between units, eliminating gaps and possible dirt traps.

Sustainability



- Kettle shall be double jacketed including high quality thermal insulation of the pan, saving energy and keeping ambient temperature low.
- Firmly fitting cover to reduce cooking time and save energy costs.
- Closed heating system – no waste of energy.
- Pressure switch control monitors energy and water consumption.

Included Accessories

- 1 of Water additive against corrosion for indirect boiling pans PNC 927222

Optional Accessories

APPROVAL: _____



Front

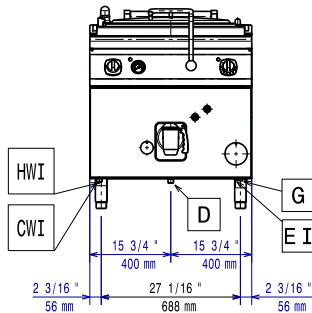

Side

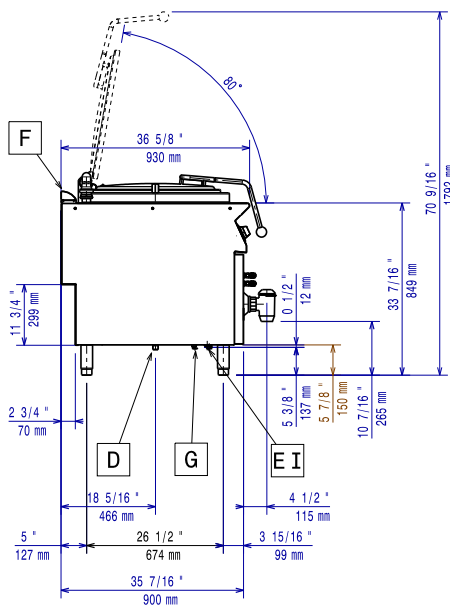

CWI = Cold Water inlet 1 (cleaning) HWI = Hot water inlet
 D = Drain
 EI = Electrical inlet (power)
 G = Gas connection

Top

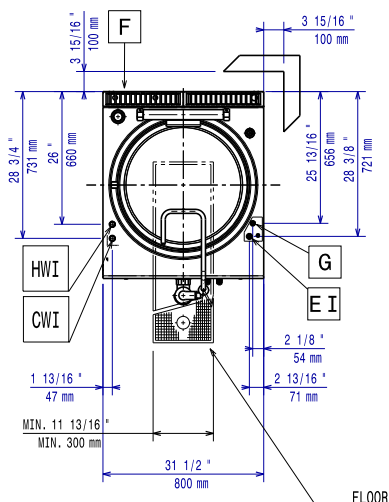

Electric

Supply voltage:
 391102 (E9BSGHIRF0) 220-230 V/1 ph/50 Hz
Total Watts: 0.1 kW

Gas

Gas Power: 24 kW
Standard gas delivery: Natural Gas G20 (20mbar)
Gas Type Option: LPG; Natural Gas
Gas Inlet: 1/2"

Key Information:

Pan useful capacity: 143 lt
Vessel (round) diameter: 600 mm
Net weight: 126 kg
Shipping weight: 141 kg
Shipping height: 1230 mm
Shipping width: 1110 mm
Shipping depth: 860 mm
Shipping volume: 1.17 m³
 No clearance needed on rear sides of unit if wall is of non combustible type. If wall is combustible, minimum 50 mm wall clearance should be maintained.
Certification group: N9PIG